

PETRA MODEL LUFFING 45/6

Load Diagrams / Yük Diyagramları

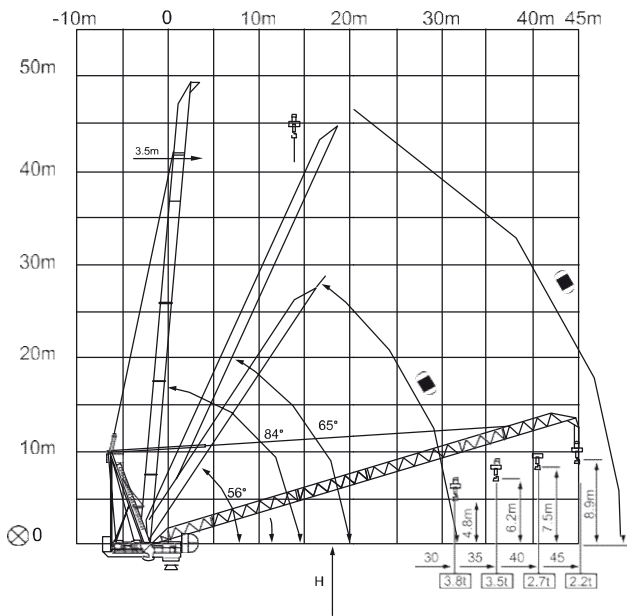

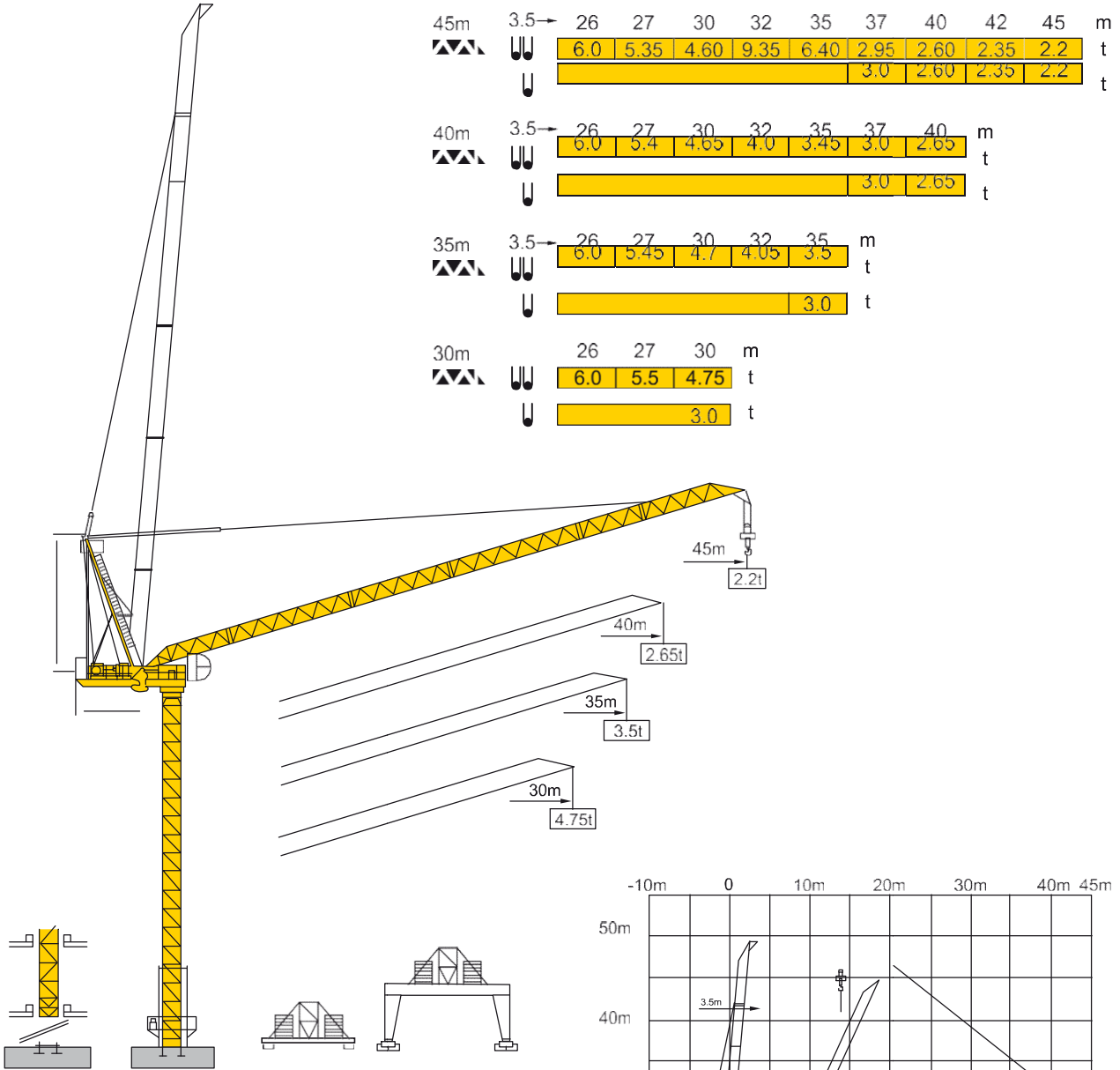

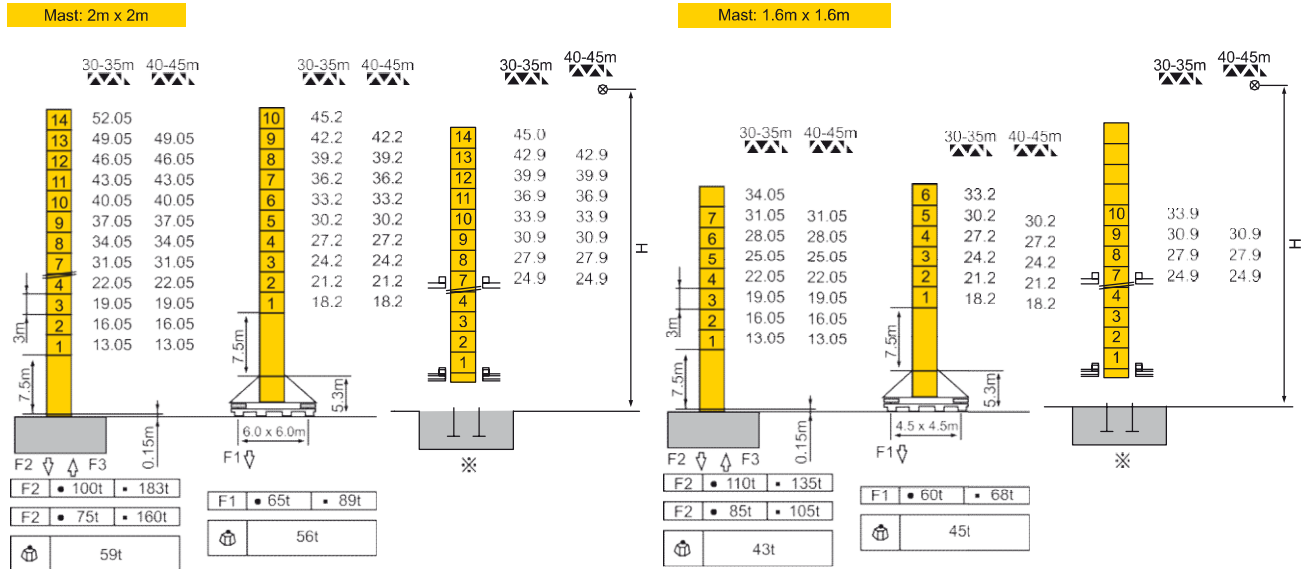

■ Weahter Vaning Position / Rüzgar Dayanma Pozisyonu.

⊗ Jib Hinge Shaft / Bom Destek Şaftı

PETRA MODEL LUFFING 45/6



Reactions / Reaksiyonlar	<ul style="list-style-type: none"> ● In service / Çalışır Durumda ■ Out of Service / Servis Dışı 	 Self-Load / Kendi Ağırlığı	Without load and counter-weight / Yüksüz ve Kuyruk Ağırlığı With longest jib and standart height / En Uzun Bomlu ve Standart Yükseklikte
--------------------------	--	--	---

Mechanizma / Mekanizma								kw	
Hoisting Kaldırma	24PC15	m/min	40	80	20	40	410* >410	40.5	
		t	3	1.5	6	3			
	30LVF	m/min	0 - 46.6	0 - 85.2	0-123.8	0 - 23.3	0 - 42.6	0 - 61.6	
		t	3	1.5	0.75	6	3	1.5	
30RW	m/min	44	88	22	44	0 - 55	30	Optional Winch / Opsiyonel Vinç	
	t	3	1.5	6	3				
Trolleying Hareketli Şaryo	30RWA	n/min	3					55	
Slewing Dönüş	RCV95	m/min	0-0.8					95x2Nm	
Travelling Hareketli	RT443	m/min	15-30					5.2 x 2	
 Power Supply / Güç Kaynağı			380v 50Hz / 440v 60Hz						
KVA Necessary Electric Power / Gereken Elektrik Gücü			RCS:100KVA LVF:*						

PETRA MODEL LUFFING 45/8

Load Diagrams / Yük Diyagramları

